

## Exhibit Awards

### Rochester Philatelic Association

- Grand Award (French 19th century bronze stamp box)
- Reserve Grand (Hand-painted ceramic stamp box)
- Single Frame Grand (Sterling silver Art Nouveau double slot stamp case pendant)
- Larry R. Moriarty Sr. Memorial Award - Judges' Award of Merit (1940s carved wooden stamp box)
- Andy Hale Award - Best Non-Postal History Exhibit by a RPA Member (book, silver round)
- Dusty Miller Award - Best Postal History Exhibit by a RPA Member (Brass Art Nouveau sunflower stamp box)
- Norman E. Wright Memorial Award- Best Railway Exhibit (book)
- LRM Popularity Award - Most Popular as Voted by ROPEX Attendees (Cup Trophy)

### American Philatelic Society

- Medal and Ribbon of Excellence - Pre-1900 Material, 1900-1940 Material, 1940-1980 Material, Post-1980 Material
- Medal and Ribbon for Research Excellence

### American Association of Philatelic Exhibitors

- Award of Honor (2) - Excellence in Presentation Not Winning a Gold (cloisonné pin)
- Creativity in Philatelic Exhibiting Award (gold pin)
- Plans and Headings Award - Best Exhibit Demonstrating These (magnifier)
- Novice Award - Best Exhibit of a First Time Exhibitor (year membership, exhibiting book)

### American First Day Cover Society

- Best Exhibit of First Day Covers- 2 or more exhibits with 75% or more FDCs (plaque, ribbon)

### American Topical Association

- First Award- Best Multi-frame Thematic Exhibit- Bronze or Higher (medal, ribbon)
- One-Frame Merit Award- Best 1 frame Thematic- Bronze or Higher (medal, ribbon)

### American Philatelic Congress

- Excellence in Written Text (Congress Book)

### Auxiliary Markings Club

- Best Exhibit of Auxiliary Markings Winning a National Silver or Higher (certificate)

### Collectors Club of Chicago

- Exhibit of Merit Winning a Vermeil or Gold Medal and Not Winning the Grand or Reserve Grand (three hardbound club publications)

### Empire State Postal History Society

- Best New York State Postal History Exhibit Winning a National Vermeil or Gold- minimum 2 entries (Autographed copy of Lowell Thomas' book, "Pageant of Adventure")

### Lighthouse Stamp Society

- Best Exhibit with a Nautical Connection (Fort Niagara ceramic lighthouse)

### Postal History Society

- Best Multi-frame Exhibit of Postal History minimum 6 entries (medal)

### United Nations Philatelists, Inc.

- Best, 2<sup>nd</sup> Best, 3<sup>rd</sup> Best Exhibit of UN, League of Nations or Related Agencies (gold, silver and bronze medals, ribbons)

### United States Philatelic Classics Society

- Best U.S. Exhibit with Greater than 75% Material up to the First Bureau Issue of 1894 Winning a National Vermeil or Gold and Not Winning this Award in 24 Months (medal)

### United States Stamp Society

- Statue of Freedom Award- Best U.S. Multi-frame Exhibit of Postage Stamps, Revenue Stamps or Stamped Paper Winning a National Vermeil or Gold (medal)

### Women Exhibitors

- Sterling Achievement Award- Merit for Any Exhibit in Philatelic/Subject Knowledge, Material or Treatment Winning a Bronze, Silver-Bronze or Silver (pin)

# ROPEX 2017

May 19-20, Greater  
Canandaigua Civic Center

Sponsored by the  
Rochester Philatelic Association

Honoring the 200<sup>th</sup> Anniversary  
of the Start of Erie Canal Construction

## Friday, May 19

- 10 AM..... Show opens, Welcome and Ribbon Cutting Ceremony, show entrance
- 10 AM-6 PM... Prize drawings throughout the day, Free Stamp Evaluations
- 6 PM..... Show closes

## Saturday, May 20

- 9:15 AM..... ROPEX Awards Ceremony (Room 1)
- 10 AM..... Show opens
- 10 AM-5 PM... Prize drawings throughout the day, Free Stamp Evaluations
- 11 AM-Noon.. Empire State Postal History Society Trading Hour and Regional Meeting (Room 1)
- Noon-1 PM.... American Association of Philatelic Exhibitors "Open Forum on Exhibiting" with Ken Martin (Room 1)
- 1-2 PM..... Judges' Feedback Forum (Room 1)
- 2-2:15 PM..... RPA Youth "Design-A-Stamp" Awards Presentation (Youth Area)
- 6 PM..... Show closes, Exhibit Pickup

## Welcome to ROPEX

Thanks for visiting ROPEX 2017! Enjoy everything the show offers—diverse dealers, fine exhibits and the fellowship of philatelists from around the country. If you're local, join us the 2<sup>nd</sup> and 4<sup>th</sup> Thursdays of most months at 7 PM at the JCC, 1200 Edgewood Ave. Yearly membership is only \$20. Sign up today at the RPA table! Here is our Show Committee:

**Awards:** Ada M. Prill  
**Awards Ceremony:** Ray Stone  
**Bourse:** Dave Robinson  
**Cachet Designs:** Tom Fortunato  
**Cachet Sales:** Carl Miller  
**Design-A-Stamp:** Frank Tritto  
**Exhibits/Judges:** Tom Fortunato  
**Hospitality Table:** Chuck Schultz  
**Program/Secretary:** Fred Haynes

**Publicity:** Tom Fortunato  
**Site Coordination:** Dave Robinson  
**Treasurer:** Dave Robinson  
**Volunteers:** Chuck Schultz  
**Youth Activities:** Mary Iman, Amy Rau and RPA Members  
**At-Large:** Paul Brach, John Lighthouse, Rick Kase, Rich Spinelli (Ex Officio)

## Philatelic Judges

William Schultz ( <i>Chief Judge</i> ) West Chester, PA	Sam Chiu Toronto, ON Canada	Ken Martin Bellefonte, PA
--	--------------------------------	------------------------------

## ROPEX 2017 Dealers

- 1 Tom's Stamps** PO Box 470, Butler, PA 16003-0470  
tomsstamps@zoominternet.net (724) 287-1931  
Classic US mint/used and worldwide stamps, lots
- 2 Dave & Joni Allego** PO Box 69, Salem, OH 44460  
dallego@neo.rr.com (234) 567-4181  
Worldwide covers, cinderellas, picture postcards, ephemera
- 3 Richfield Philatelic Company** 113 Richfield Ave, Buffalo, NY 14220  
billwits@aol.com (716) 826-1242  
US and worldwide stamps and covers, collection lots
- 4 Doubleday Postal History** PO Box 70, Rindge, NH 03461  
doub@worldpath.net (603) 899-9085  
US postal history
- 5 Lou Atvell** 24 Bayberry Dr, Rochester, NY 14609-2002  
latvell@twc.com (585) 288-4240  
US and worldwide
- C1 Armstrong Cachets** PO Box 24663, Rochester, NY 14624-4663  
karmstr2@rochester.rr.com  
US FDCs

95-96 **10¢ Canal Boat Transportation Coil** *Raymond Stone* (Non-Competitive)

97-104 **The United Nation's 4¢ and 11¢ World United Against Malaria Set of 1962 and their First Days** *Larry Fillion*  
This is a multi-frame "traditional" first day exhibit of the United Nation's 4¢ and 11¢ World United Against Malaria set of 1962. (Illustrated Mail)

105-108 **Porte de Mar Stamps of Mexico and their Forgeries** *Benedict A. Termini, M.D.*  
This exhibit showcases stamps used to pay Mexican sea postage from 1875 to 1879, and their forgeries. (Postal)

109-118 **Woody Guthrie: His Life and His Songs** *Stephen L. Suffet\** Display exhibit recounts the life and illustrates some of the song lyrics of one of the USA's most influential folk musicians. (Display)

119 **Black Jacks** *John Flannery III\**  
A comprehensive study displaying all varieties of this classic two cent stamp first issued during the Civil War in 1863, including several on cover. (Postal)

120 **Attilio Gatti, African Adventurer** *Regis Hoffman*  
This single-frame exhibit chronicles the adventures of Attilio Gatti, an Italian cavalry officer, who developed a love for African exploration. (Display)

121 **Competitive Rowing Errors and the Unexpected** *Clemens Reiss*  
Stamp designers seldom understand this sport which leads to design errors. The rowers themselves have been involved in some odd events and achievements. (Postal)

122 **Auxiliary Markings On United Nations New York FDCs Sent To Domestic United States Addresses** *Larry Fillion*  
A single frame exhibit of domestic first day covers posted from UN-NY headquarters bearing a variety of markings showing mail gone astray. (Postal)

123 **The Bridges of Hartford, 1810 to Mid-1940s** *Anthony F. Dewey*  
The story of the succession of bridges spanning the Connecticut River at Hartford, from the first bridge in 1810 to the current bridge via postcards. (Postcard)

124 **One Man's Mission- the United Kingdom 1864 Penny Reds** *Larry Rausch\**  
Included is one reconstructed plate and sections on overprint and underprint, perfins, postmarks, stamps and covers, along with covers to USA. (Postal)

125 **Along the Shantung Railway, China: German Postal Administration 1900-1914** *Louis P. Pataki*  
A postal history exhibit showing the development of the German postal administration associated with the Shantung Railway. (Postal)

126 **Usages of the U.S. World United Against Malaria Commemorative Issue of 1962** *Larry Fillion*  
Sixteen pages showing a variety of uses of the 4 cent U.S. issue of March 30, 1962 raising awareness of worldwide malaria eradication. (Postal)

127 **The "D" Rate-Change Stamps of 1985** *Anthony F. Dewey*  
The non-denominated (22c) "D" stamps issued for the rate increase in 1985 from 20c for first class letters. (Postal)

128 **Great Britain Plate Numbers** *Edward Bailey* (Non-Competitive)  
A look at plate numbers appearing on various issues of Great Britain from 1858-1881.

## ROPEX 2017 Exhibits

\* Exhibiting RPA Member

- 1-10 **Mail From Along The Erie Canal: 1825-1862** *Anonymous*  
This display exhibit uses mail emanating from places along the Canal and related non-philatelic items from the period to tell the story of its impact. (Display)
- 11-18 **The Sullivan Commemorative of 1929** *Alan Parsons\**  
Background, production, FDCs (official/unofficial), and commercial uses of this U.S. commemorative issued June 17, 1929 for the American Revolution's Sullivan-Clinton Campaign 150th anniversary. (Postal)
- 19-26 **A Postal History of Hartford, Connecticut** *Anthony F. Dewey*  
The postal history of the United States via Hartford, CT from 1792 through 1897 when Hartford opened its first branch office. (Postal)
- 27-36 **United States Domestic Letter Rates, Act of 1792 Through the Act of 1872** *Robert P. Meegan\**  
A study of the domestic letter rates in effect from the first Federal Postal Act of 1792 to 1883, and the social and economic factors applicable to the U.S. postal system. (Postal)
- 37-41 **Corning, NY Postal History Including DPOs Now Served by the Corning Post Office** *Alan Parsons\**  
An examination of mail handling from 1834 to date in the area now covered by the Corning, NY Post Office. (Postal)
- 42-46 **British and Guernsey Stamps and Their Use During German Occupation; 1940-45** *Andrew Mazzara*  
Exhibit shows how German occupation affected the design, printing, and use of British and local Guernsey stamps. (Postal)
- 47-55 **The Beleaguered Mark: Keeping Pace With the Great German Inflation of 1919-1923** *Jeffrey Shapiro*  
Chronicling the attempts at postal order during the economic chaos which devastated Germany following World War I. (Postal)
- 56-64 **U.S. Revenue Stamps- First Issue "Using the Documents of Commerce to Fund the Civil War 1862-1872"** *John Lighthouse\**  
This revenue fiscal history exhibit is focused on the First Issue revenue stamped documents taxable under the Tax Act of 1862, Schedule B. (Revenue)
- 65-74 **Chinese Inflation Run Amok: 41 Months of Hyperinflation** *Henry Sweets*  
Study of the Chinese inflation period 1945-1949 as documented on mail to the United States. (Postal)
- 75-84 **The W.H.O.'s "The World United Against Malaria" Stamp Campaign** *Larry Fillion*  
This exhibit will showcase the 150+ philatelic issues which were part of the WHO/United Nation's sponsored "The World United Against Malaria" stamp campaign. (Topical)
- 85-88 **Identification and Use of United Kingdom One Penny (1d) Perfins 1868-1880** *Larry Rausch\**  
An alphabetical distribution of Penny Red commercial perfins (PERForated INsignia or INitials) from 1868 to 1880 on stamps and covers. (Postal)
- 89-94 **1898 Canada Map Stamp: A Plating Study** *Robert Lighthouse\**  
Plating anomalies and errors of Canada Scott numbers 85 and 86 illustrated through singles, blocks, imperfs and covers. (Postal)

- 6 **S & C Resnick** 2783 W Lake Rd, Cazenovia, NY 13035  
resn@aol.com (315) 655-2810  
Postal history, stamps, ephemera
- 7 **Canterbury Stamps** 10 Chaucer Rd, Nashua, NH 03062  
adaptron@comcast.net (603) 888-4317  
Worldwide, US (singles and mint sheets), topicals
- 8 **McCloud Stamps & Covers, Coins** 109 Maple Center Rd, Hilton, NY 14468  
jstoltz@rochester.rr.com (585) 507-3533  
US, Canada, Br. Commonwealth, France, US coins
- 9 **Telah W. Smith** 1145 Columbus Cir N, Ashland, OH 44805  
telah@telahsmith.com (419) 289-2401  
Worldwide stamps (no US), including Machins and Exportas, topicals
- 10 **Al Greco Stamps** 1190 Nolan Rd, Macedon, NY 14502  
alfredgreco@verizon.net (315) 986-7948  
US and worldwide stamps, US and Canadian revenues
- 11 **1840-1950 Mostly Stamps** PO Box 423, Milford, NH 03055-0423  
hstamps@jlc.net (603) 673-7180  
US, British Empire, worldwide and Scott catalogues
- 12 **Laurence L. Winum** PO Box 247, Walden, NY 12586-0247  
winum@frontiernet.net (800) 914-8090  
US and Germany stamps and covers
- 13 **R.J. Associates** PO Box 774, Bradford, PA 16701-0774  
cry@atlanticbb.net (814) 362-4471  
US, topicals, foreign classics
- 14 **Donofrio Philatelics** 110 Chestnut Dr, Rochester, NY 14624  
loofer@rochester.rr.com (585) 747-7218  
US, Canada and worldwide stamps
- 15 **Suburban Stamp and Coin** PO Box 2338, Syracuse, NY 13220  
merristamp@aol.com (315) 452-0593  
US and worldwide stamps, US coins
- 16 **The Cover Connection** 2884 Seneca St, West Seneca, NY 14224  
coverconnection@gmail.com (716) 854-0222  
US and worldwide covers
- 17 **Stamp Smith** 1212 NE 96th Terrace, Kansas City, MO 64155-2149  
smidale@umkc.edu (816) 734-4536  
Topicals, US, worldwide and covers

Knowledgeable members of the RPA will be happy to identify and evaluate your stamps and philatelic holdings free of charge. Just bring them to our tables near the entrance.

Joining us are APS Chief Operating Officer Ken Martin who is one of our judges, ATA President Dale Smith manning his booth (#17), and officers of the Empire State Postal History Society staffing their group's booth.

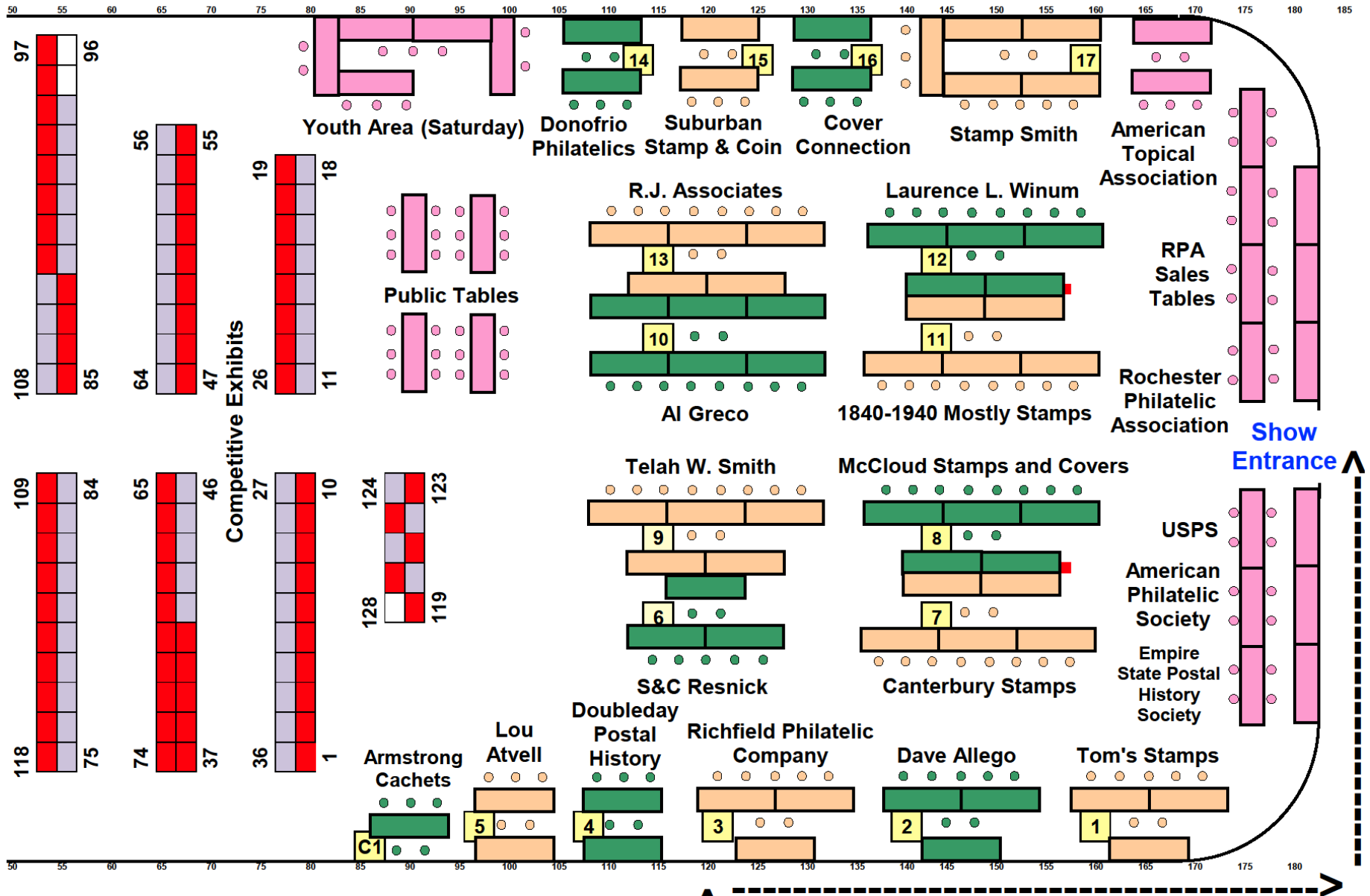

Make sure to visit the RPA tables for a selection of 10 cent worldwide stamps, covers, better items and collections for sale. All proceeds support year-round club activities.

Membership special! Join our 2017-18 season starting in July for \$20 and get the next 2 months (May and June) free!

**Building Entrance**

**Meeting Room 1**

Knowledgeable members of the RPA would be happy to identify and review your stamps and philatelic holdings free of charge to give you an idea of what you have. Bring them to our tables near the entrance.