

Rochester Philatelic Association Membership Application

- \$20 Adult Membership
- \$20 Family Membership (+\$5 per additional member)
- \$5 Youth Membership (<18)

Please Print:

Name _____

Address _____

City _____ St _____ Zip _____

Phone _____ Birth Year _____

Email _____

Society Memberships (include membership #)

APS # _____ ATA # _____ RPSC # _____

Additional Family Membership Names

Name _____

Name _____

RPA memberships run from July 1-June 30 of the following year. Membership dues above are for the 12 month period. Make checks payable to: Rochester Philatelic Association, mentioning "membership dues" on the "For" line. Mail to:

Rochester Philatelic Association
PO Box 10206 Brighton Station
Rochester, NY 14610-0206

ROPEX 2012

An APS "World Series of Philately" Event

May 18-20

The Sports Centre at
Monroe Community
College, Rochester, NY

Honoring the 100th
Anniversaries of the Titanic
and the Rochester
Numismatic Association



A Presentation of the Rochester
Philatelic Association
www.rpastamps.org

Welcome to ROPEX 2012!

The 85 members of the Rochester Philatelic Association from throughout the region are happy that you can join us along with several hundred fellow philatelists to our biggest event of the year.

ROPEX 2012 (short for Rochester Philatelic Exhibition) follows a tradition of more than 75 years of stamp shows managed by our club. Not all of our shows have been so grand. In fact, the earliest featured simple table displays and perhaps three or four dealers. We expect some 26 dealers this year and a full complement of 125 frames of competitive exhibits, as well as participation by our friends from the Rochester office of the U.S. Postal Service selling the latest stamp issues and offering our three commemorative postmarks.

We chose two noteworthy centennial anniversaries as our themes this year, one with a local connection and the other known around the world.

Our sister coin club, the Rochester Numismatic Association (www.the-rna.com), was actually formed a year before the RPA. Then as now some collectors were members of both organizations, sharing their knowledge and passion for both hobbies with each other and the community.

Who doesn't know the story of R.M.S. Titanic? Stamp collectors above all others understand the significance of those preceding initials, standing for "Royal Mail Ship." Seven million pieces of mail sank with the ship, along with more than 1,500 lives that were lost in the tragedy. It is in reverence that we honor its maiden voyage and especially the passengers and crew, both survivors and the fallen.

Enjoy the show and get ready for our 100th anniversary exhibition in 2013. We'll be joined by the American Topical Association presenting "ROPEX-NTSS: Two Shows in One" with 50 dealers and 250 exhibit frames!

ROPEX Titanic Centennial Station
May 19, 2012 Rochester, NY 14623

RMS TITANIC
Honoring the Crew, the Passengers and Those Who Died Among Them

We are pleased to offer our special cancels and cacheted envelopes during the show.
Pair of Titanic covers- \$5
RNA Centennial cover- \$2
Mail orders- please add 50 cents per cover.
RPA, PO Box 10206, Rochester, NY 14610

The Judging Panel

Our chief judge, Charles Verge, hails from Toronto, Ontario Canada. Charles is currently Secretary and Director of the Vincent Graves Greene Philatelic Research Foundation. He was President of The Royal Philatelic Society of Canada from 2000 to 2007, President of the American Association of Philatelic Exhibitors (1998-2002) and is a Past President of the Eire Philatelic Society. A national and international collector and accredited judge, he has represented Canada at many international shows, most recently at Monacophil 2011.

Allison Cusick is a life member of both the American Philatelic Society and the American First Day Cover Society. He also serves on the Expertizing Committees of both organizations. He has authored numerous articles for First Days, Linn's Stamp News, The American Philatelist and other hobby publications, as well as the Photo Encyclopedia of Linprint Cachets. Allison has been an accredited APS judge since 2002. His specialties are US and Canadian postal history, illustrated mail and postcards.

Joseph (Joe) F. Frasch, Jr. comes to us from Columbus, Ohio and is an attorney in private practice. Joe has been an accredited APS judge since 2005 and is an accredited American Topical Association judge. He has a Diamond Award from the AAPE and has exhibited in the WSP Champion of Champions and Ameristamp Expo single frame Champion of Champions. He holds membership in several societies, including the APC, ATA, AAPE, AAMS, PHS and USSS. Specialties include thematic, single frame, US postal history and US revenues.

Dominick Riccio is a psychologist-psychanalyst who has been collecting stamps since 1974 as a way of exploring his family heritage. He collects postal history, Eastern Europe, U.S. Revenues, Ireland, Greenland, Ryukyus, Faroe Islands and Danish West Indies, specializing and exhibiting internationally in material from Czechoslovakia and Carpatho-Ukraine. He is a past president of the Society for Czechoslovak Philately and has been the editor and a writer for the "Czech Philatelist". A national judge since 1987, Dr. Riccio is a firm believer in the therapeutic effects of philately for its great source of pleasure and gratification.

Jeffrey Shapiro, a collector since age 6 and a 26 year APS member, has philatelic interests in US 20th century postal history, the post-WWI German inflation period and worldwide aerophilately. He is a gold medal winning exhibitor, national judge since 2001 and a well respected philatelic writer. A member of four Boston-area stamp clubs and several national organizations, Jeff is current VP of the United States Stamp Society, a Board member of the Cardinal Spellman Philatelic Museum and for the past 15 years chairman of "Philatelic Show," another WSP exhibition held annually in Boxborough, MA.

A collector since age 7, apprentice Jack Thompson specializes in the land of his birth, Cuba. His primary area of philatelic research is the Spanish American War, the U.S. Administration in Cuba and the Cuban Revolutionary mail of that period. He has published several articles in the Cuban Philatelist and most recently was editor of the second edition of the Handbook of the Stamps of Cuba, printed in 2011. Jack has been a member of the Board of Directors of the Cuban Philatelic Society for many years and has run their club auctions since 2005. He has won gold medals for several exhibits and won the Grand at Denver's ROMPEX 2009.

90-96 **The 6c Theodore Roosevelt Definitive Stamp 1955-1968** Joann and Kurt Lenz [Postal] This traditional exhibit presents the production, issued stamps, and usages of the 6c Roosevelt stamp of the Liberty Series.

97-98 **Identification of the Regularly Issued United State Bank Note Issues of 1870 to 1890** Robert P. Meegan* [Postal] An introductory tutorial of the designs, plate arrangements, papers, grills, and examples of printing variations of the Large Bank Note issues of 1870 to 1890.

99-108 **The United States Large Bank Note Issues of 1870 to 1890** Robert P. Meegan* [Postal] A study of the usage of the U.S. Large Bank Note Issues and the rates in effect for domestic, territorial, and international mail.

109-111 **U.S. Revenue Stamps- First Issue: Using Commerce to Fund the Civil War** John Lighthouse* [Revenue] This postal history exhibit covers the usage of U.S. first issue revenue stamps on documents during the Civil War and post-Civil War era.

112-120 **Penny Black Plates- The Stamps, Varieties and Usage** Graham Locke [Postal] The story of the Penny Black (and reds), the stamps themselves, the many varieties found and examples of their usage.

121-125 **A Plating Study of the 1998 Canadian Map Stamp** Robert W. Lighthouse* [Postal] A plating study of unique criteria and anomalies of plates 1,2,3 and 5 including mint, used, multiples, covers and imperf examples.

Major Exhibit Awards - Stamp Boxes

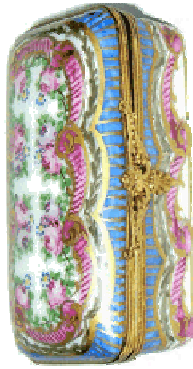

Grand- Limoges Porcelain

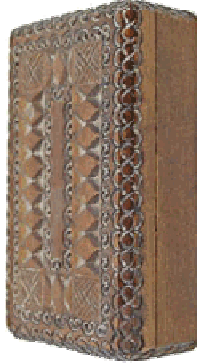

Reserve Grand- European Wood



One Frame Grand- Chinese Cloisonné Brass



Miller Award- Metal



Moriarty Award- Dutch Frisian Island Wood

*Award
to be
Selected*

Andy Hale Award

2012 Schedule & Events

All meetings are open to the public except as noted*. Meeting rooms are on the upper level accessible through the right double doors.

Thursday, May 17

8 AM-6 PM..... Setup (exhibitors and dealers welcome 1-6 PM)

Friday, May 18

8 AM-6 PM..... Judges' Deliberation Room (Room 1*)
9:30-11 AM..... "Early Bird" Bourse- \$20 entry fee for interested collectors and dealers

11 AM..... Show opens, Welcome Remarks (show entrance)

11 AM-6 PM... Prize drawings throughout the day

6 PM..... Show closes

Saturday, May 19

10 AM..... Show opens

10 AM-5 PM... Prize drawings, youth activities throughout the day

10-11 AM..... ACE-Art Cover Exchange Meeting (Room 1)

Noon-5 PM.... Cachet Makers' Bourse

Noon-1 PM.... Empire State Postal History Society Trading Hour (Room 1)

1-2 PM..... Empire State Postal History Society Annual Meeting (Room 1)

1-2 PM..... Walk-Through Discussion of the Exhibits (Frame 1)

2-3 PM..... American Association of Philatelic Exhibitors "Open Forum on Exhibiting" (Room 1)

3-4 PM..... Judges' Feedback Forum (Room 1, then at the Frames)

5 PM..... Show closes

6 PM..... ROPEX Awards Banquet- Cerame's Italian Villa, cocktails 6-7, dinner 7 PM

Sunday, May 20

10 AM..... Show opens

10 AM-3 PM.. Prize drawings, youth activities throughout the day

1 PM..... RPA Youth "Design-A-Stamp" Awards Presentation (show floor exhibit frames)

3 PM..... Show closes

3 PM..... Exhibitor's Reception and Exhibit Pickup

The ROPEX Committee

Awards: Ada Prill

Banquet: Ray Stone

Bourse: Dave Robinson

Cachet and Cancel Designs:

Tom Fortunato and Joe Doles

Cachet Sales: Rick Kase

Design-A-Stamp: Frank Tritto

Exhibits: Tom Fortunato

Judges: Ann Triggler

Publicity: Tom Fortunato

RPA Hospitality Table: Chuck Schultz

Staging: Rick Kase

Treasurer: Dave Robinson

Youth Activities: Mary Iman

Advisors: John Lighthouse, Bob Meegan, Carl Miller

With thanks to the entire RPA membership!

Dealers

- 17 **1840-1950 Mostly Stamps** hstamps@jlc.net
PO Box 423, Milford, NH 03055-0423 (603) 673-7180
US, British Empire and worldwide- stamps, covers, lots
- 2 **Dave & Joni Allego** dallego@neo.rr.com
PO Box 69, Salem, OH 44460 (234) 567-4181
Worldwide covers, cinderellas, ephemera
- 20 **David Alex**
PO Box 2176, Glenview, IL 60025 (847) 253-9872
US stamps, plate blocks, postal stationery, US possessions
- 19 **Amberman Postal History** ambermanpostal@aol.com
PO Box 4700, Clifton Park, NY 12065 (518) 280-2125
US 19th and 20th century covers
- 8 **Bardo Stamps** jfb7437@aol.com
PO Box 7437, Buffalo Grove, IL 60089-7437 (847) 634-2676
US #1 to present
- 13 **Boilermaker Stamps** rusty.shoaf@rshoaf.com
1233 Southlake Ave E, Greenwood, IN 46143 (317) 289-7696
US stamps and revenues, US and worldwide covers
- 12 **Boilermaker Dollar Table**
Everything for a dollar or less.
- 7 **Britannia Enterprises** michael.e.mead@verizon.net
PO Box 2114, Orleans, MA 02653-2114 (508) 255-2465
Worldwide covers, cinderellas, ephemera
- 6 **Brunelle Stamps & Coins**
25 E Broadway, Derry, NH 03038 (603) 432-2658
US and worldwide stamps, US and worldwide covers
- 21 **The Cover Connection** coverconnection@gmail.com
PO Box 173 Niagara Square Sta., Buffalo, NY 14201 (716) 854-0222
US and worldwide covers
- 24 **Finger Lakes Stamps** abanhani@rochester.rr.com
PO Box 5, Shortsville, NY 14545 (585) 289-6395
Switzerland and worldwide stamps and covers
- 5 **Al Greco Stamps** alfredgreco@verizon.net
1190 Nolan Rd, Macedon, NY 14502 (315) 986-7948
US and worldwide stamps, US and Canadian revenues
- 10 **Gerald Gonyea**
PO Box 207, Moira, NY 12957-0207
US and worldwide stamps

- 32-36 **African Countries Under the Southern Hemisphere** Anthony Manoussakis [Display] The first definitive and commemorative issues of independent African countries below the equator in their historical context.
- 37-40 **Everybody Must Get Stoned (but not Bob Dylan's version)** Eleanor A. Steeb* [Display] The exhibit discusses all manner of stones from early man to the present. Covers aspects of discovery, usage, fascination and myths as well as related aspects.
- 41-43 **What's a Telephone Good For?** Ada M. Prill* [Postcard] Picture postcards show how views evolved about the use of the telephone in everyday American life in the early 20th Century.
- 44-46 **United States Non-Denominational "A" Eagle Rate Change Stamp** David T. Robinson* [Postal] A first day cover exhibit arranged in alphabetical order of cachet designers showing all formats the stamps were issued in.
- 47 **A Whimsical Study of Transportation Using First Day Covers to Tell the Story** Raymond M. Stone* [Postal] A fun look at various modes of transportation as seen through stamps and cachets on first day covers.
- 48-50 **Transportation Coils as Seen Through First Day Covers** Raymond M. Stone* [Postal] This collection has a first day cover for every transportation coil stamp that had an official first day of issue.
- 51-54 **Uses of the Second Postage Due Issue of Israel - 1951 to 1953** Howard Rotterdam [Postal] An exhibit of covers demonstrating the uses of the second postage due issue of Israel, both domestic and incoming from other countries.
- 55-60 **Washington and Franklin Rotary Press Coils 1914-1922 Perforated 10 Issues Production & Uses** Gregory Shoultz [Postal] This exhibit features the production of the rotary press coils including coil waste along with domestic and foreign uses of the issues on cover.
- 61-68 **Lemberg: Cosmopolitan Crownland Capital of the Austrian Empire** Inger Kuzych [Postal] Postal history - spanning 150 years of the Austrian Empire's expansion - that came from, went to, or passed through Lemberg, one of its crownland provincial capitals.
- 69-75 **Falklands or Malvinas?** Mark A. Butterline [Postal] An historical and social exhibit examining the philatelic manifestations of the contest for the islands, starting in 1927 and continuing up to 2002.
- 76-82 **Great Britain: Queen Elizabeth II Pre-Decimal Civilian Postage Rates** Duncan Barber* [Postal] Postal history exhibit of GB QEII civilian postal Rates from her ascension (6 February 1952) to the day before decimalization (14 February 1971).
- 83-89 **The Sullivan Commemorative of 1929** Alan Parsons* [Postal] Background, production, FDCs (official/unofficial), and commercial uses of this U.S. commemorative issued June 17, 1929 for the American Revolution's Sullivan-Clinton Campaign 150th anniversary.

Exhibits by Frame Number

(* denotes an RPA member)

- 1 **Washington and Franklin Coils 1914 Issue** Gregory Shoultz [Postal]
A single frame exhibit featuring the production and use of the 1914 flat plate coil issue on domestic and foreign destinations.
- 2 **This Land Is Your Land: the Story of a Song** Stephen L. Suffet* [Display]
This single frame display division exhibit looks at a song that has been called America's Folk Song National Anthem.
- 3 **Courageous Founding Fathers** Edward J. Bailey [Postal]
A single frame exhibit of our founding fathers on stamps from 1847-1939.
- 4 **History of US Stamps- The One Cent Values** Edward J. Bailey [Postal]
A single frame exhibit of U.S. stamps, both definitives and commemoratives, all with a one cent denomination.
- 5 **U.S. Test Stamps Related to the B.E.P. (ca. 1907-1959)** Joann and Kurt Lenz [Postal]
A study of BEP testing items; includes items to test Stickney rotary press, private perforations, and BEP processing equipment.
- 6 **E-COM and its Forerunners** Joann and Kurt Lenz [Postal]
This exhibit documents USPS electronic services in which volume mailers' messages were transmitted to POs for first class delivery.
- 6A-H **Canada Imperial Penny Post** Orville Osborne [Postal]
Canada's Imperial Penny Post, The Xmas Stamp, during its pre-production phases including the printing in two distinct colors.
- 7-12 **AMG Germany... Postal Cards... The 1945 "M" Design** Paul L. Baker [Postal]
Study of the 1945 "M" Postal Cards issued in the American & British Zones. Includes history, types, color varieties, paper types, errors, uses, up-ratings, etc.
- 13-16 **Questions of Source, Fact, and Fiction re: King Arthur, His Knights, and the Legends About Them** Karen Barber* [Thematic]
A look at the logical possible ways in which the legends about Arthur and his knights could have developed and propagated and become a story.
- 17-21 **Angels in the Judeo-Christian Era** Alice Johnson* [Thematic]
A thematic exhibit detailing the history of angels through the millennia.
- 22-26 **The Diversity of Ceramics and Ceramic Materials** Thomas M. Fortunato* [Thematic]
A thematic exhibit exploring common everyday items made of primarily inorganic compounds from their raw materials, to forming, to firing and end products.
- 27-31 **Her Majesty Queen Elizabeth II** Alyssah Xeniah C. Alcalá [Youth age 18]
The illustrious life of Queen Elizabeth II and the British empire under her reign.

- 11 **Lindner Publications** lindner@lindner-usa.com
PO Box 5066, Syracuse, NY 13220 (315) 437-0463
Supplies, gifts and accessories <http://www.lindner-usa.com>
- 9 **McCloud Stamps & Covers** jstoltz@rochester.rr.com
109 Maple Center Rd, Hilton, NY 14468 (585) 392-3599
US, Canada, France, worldwide
- 22 **McGowan Covers** geolotus2003@nycap.rr.com
PO Box 482, East Schodack, NY 12063-0482 (518) 479-4396
Worldwide covers
- 4 **Northmont Books and Stamps** aitbkstps@aol.com
35375 Northmont, Farmington Hills, MI 48331 (248) 553-7667
Classic Europe and Colonies, Canada, Australia, New Zealand
- 16 **Denny Peoples**
8141 Springwater Dr W, Indianapolis, IN 46256 (317) 841-8162
US covers and postcards, revenues, cinderellas, ephemera
- 25 **Plateblockets.** plateblocket@yahoo.com
PO Box 2552, Fort Myers Beach, FL 33932-2552 (678) 595-7827
US stamps and more
- 23 **Richfield Philatelic Company** billwits@aol.com
113 Richfield Ave, Buffalo, NY 14220 (716) 826-1242
US and worldwide stamps and covers, collection lots
- 26 **Smythe's Stamp Shoppe** dgm2518@msn.com
507 Vilas St, Onalaska, WI 54650 (608) 783-6328
Worldwide topical new issues
- 14 **Suburban Stamp & Coin** merristamp@aol.com
PO Box 2378, Syracuse, NY 13220 (315) 452-0593
US and worldwide stamps, US coins
- 1 **Tom's Stamps** tomsstamps@zoominternet.net
PO Box 470, Butler, PA 16003-0470 (724) 287-1931
Classic US mint/used and worldwide stamps, lots
- 3 **Douglas Weisz US Covers** weiszcovers@yahoo.com
PO Box 1458, McMurray, PA 15317-1458 (773) 914-4332
US covers (including FDCs, navals, flights, events)
- 15 **Laurence L. Winum** winum@frontiernet.net
PO Box 247, Walden, NY 12586-0247 (800) 914-8090
US and Germany stamps and covers
- 18 **Fred Zaganiacz Stamps** fzaganiacz@comcast.net
2339 Lambeth Dr, Pittsburgh, PA 15241 (412) 833-6441
Worldwide stamps/covers, US covers, topicals
- C1 **Armstrong Cachets** karmstr2@rochester.rr.com
Rochester, NY <http://www.armstrongcachets.com>

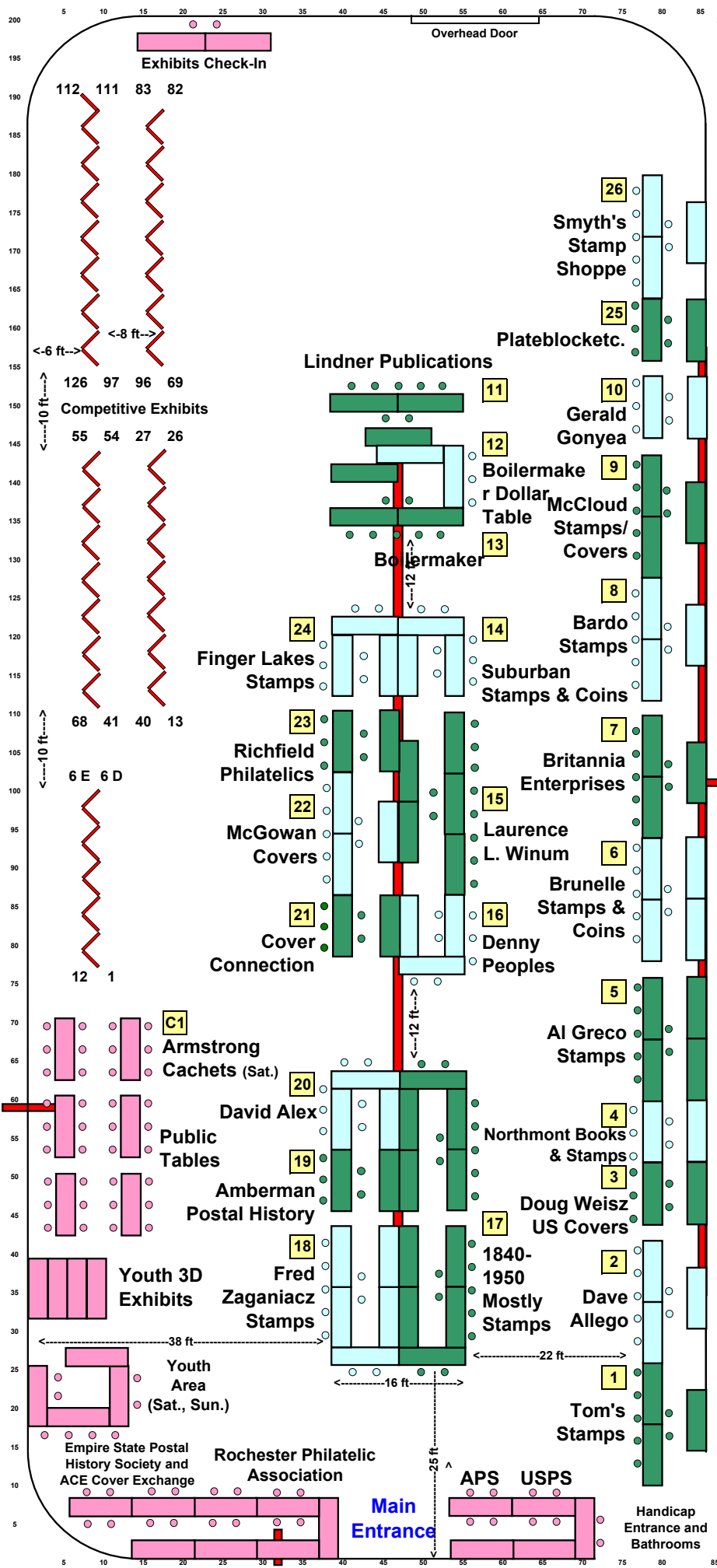

| | | | | | | |
|----|--|----------------------------|-----|---------------------------|--|--|
| 12 | AMG Germany ... Postal Cards ... the 1945 "W" Design | Canada Imperial Penny Post | 126 | X | A Plying Study of the 1898 Canadian Map Stamp | Penny Black Plates - The Stamps, Varieties and Usage |
| 11 | This 1914 Collis Land | | 125 | Identify Bank Note Issues | The United States Large Bank Note Issues of 1870 to 1890 | U.S. Revenue Stamps - First Issue |
| 10 | Coura 1 Cent (Father) | | 124 | | | |
| 9 | Test Value Stamp COM | | 123 | | | |
| 8 | | | 122 | | | |
| 7 | | | 121 | | | |
| 6E | | | 120 | | | |
| 6F | | | 119 | | | |
| 6G | | | 118 | | | |
| 6H | | | 117 | | | |
| 6E | | | 116 | | | |
| 6F | | | 115 | | | |
| 6G | | | 114 | | | |
| 6D | | | 113 | | | |
| 6E | | | 112 | | | |
| 6F | | | 111 | | | |
| 6G | | | 110 | | | |
| 6D | | | 109 | | | |
| 6E | | | 108 | | | |
| 6F | | | 107 | | | |
| 6G | | | 106 | | | |
| 6D | | | 105 | | | |
| 6E | | | 104 | | | |
| 6F | | | 103 | | | |
| 6G | | | 102 | | | |
| 6D | | | 101 | | | |
| 6E | | | 100 | | | |
| 6F | | | 99 | | | |
| 6G | | | 98 | | | |
| 6D | | | 97 | | | |
| 6E | | | 96 | | | |
| 6F | | | 95 | | | |
| 6G | | | 94 | | | |
| 6D | | | 93 | | | |
| 6E | | | 92 | | | |
| 6F | | | 91 | | | |
| 6G | | | 90 | | | |
| 6D | | | 89 | | | |
| 6E | | | 88 | | | |
| 6F | | | 87 | | | |
| 6G | | | 86 | | | |
| 6D | | | 85 | | | |
| 6E | | | 84 | | | |
| 6F | | | 83 | | | |
| 6G | | | 82 | | | |
| 6D | | | 81 | | | |
| 6E | | | 80 | | | |
| 6F | | | 79 | | | |
| 6G | | | 78 | | | |
| 6D | | | 77 | | | |
| 6E | | | 76 | | | |
| 6F | | | 75 | | | |
| 6G | | | 74 | | | |
| 6D | | | 73 | | | |
| 6E | | | 72 | | | |
| 6F | | | 71 | | | |
| 6G | | | 70 | | | |
| 6D | | | 69 | | | |
| 6E | | | 68 | | | |
| 6F | | | 67 | | | |
| 6G | | | 66 | | | |
| 6D | | | 65 | | | |
| 6E | | | 64 | | | |
| 6F | | | 63 | | | |
| 6G | | | 62 | | | |
| 6D | | | 61 | | | |
| 6E | | | 60 | | | |
| 6F | | | 59 | | | |
| 6G | | | 58 | | | |
| 6D | | | 57 | | | |
| 6E | | | 56 | | | |
| 6F | | | 55 | | | |
| 6G | | | 54 | | | |
| 6D | | | 53 | | | |
| 6E | | | 52 | | | |
| 6F | | | 51 | | | |
| 6G | | | 50 | | | |
| 6D | | | 49 | | | |
| 6E | | | 48 | | | |
| 6F | | | 47 | | | |
| 6G | | | 46 | | | |
| 6D | | | 45 | | | |
| 6E | | | 44 | | | |
| 6F | | | 43 | | | |
| 6G | | | 42 | | | |
| 6D | | | 41 | | | |
| 6E | | | 40 | | | |
| 6F | | | 39 | | | |
| 6G | | | 38 | | | |
| 6D | | | 37 | | | |
| 6E | | | 36 | | | |
| 6F | | | 35 | | | |
| 6G | | | 34 | | | |
| 6D | | | 33 | | | |
| 6E | | | 32 | | | |
| 6F | | | 31 | | | |
| 6G | | | 30 | | | |
| 6D | | | 29 | | | |
| 6E | | | 28 | | | |
| 6F | | | 27 | | | |
| 6G | | | 26 | | | |
| 6D | | | 25 | | | |
| 6E | | | 24 | | | |
| 6F | | | 23 | | | |
| 6G | | | 22 | | | |
| 6D | | | 21 | | | |
| 6E | | | 20 | | | |
| 6F | | | 19 | | | |
| 6G | | | 18 | | | |
| 6D | | | 17 | | | |
| 6E | | | 16 | | | |
| 6F | | | 15 | | | |
| 6G | | | 14 | | | |
| 6D | | | 13 | | | |
| 6E | | | 12 | | | |
| 6F | | | 11 | | | |
| 6G | | | 10 | | | |
| 6D | | | 9 | | | |
| 6E | | | 8 | | | |
| 6F | | | 7 | | | |
| 6G | | | 6 | | | |
| 6D | | | 5 | | | |
| 6E | | | 4 | | | |
| 6F | | | 3 | | | |
| 6G | | | 2 | | | |
| 6D | | | 1 | | | |

EXHIBIT LAYOUT

The exhibit awards Palmares will be posted online by the Saturday evening of the show at www.rpastamps.org

| | | |
|----|---|--|
| 13 | Questions of Source, Fact, and Fiction re: King Arthur | Angels in the Judo-Christian Era |
| 14 | Everybody Must Get Stoned (but not Bob Dylan's version) | African Countries Under the Southern Hemisphere |
| 15 | Her Majesty Queen Elizabeth II | The Diversity of Ceramics and Ceramic Materials |
| 16 | The Theodore Roosevelt Definitive Stamp 1955-1968 | Falklands or Malvinas? |
| 17 | The Sullivan Commemorative of 1929 | Great Britain: Queen Elizabeth II Pre-Decimal Civilian Postage Rates |
| 18 | | |
| 19 | | |
| 20 | | |
| 21 | | |
| 22 | | |
| 23 | | |
| 24 | | |
| 25 | | |
| 26 | | |
| 27 | | |
| 28 | | |
| 29 | | |
| 30 | | |
| 31 | | |
| 32 | | |
| 33 | | |
| 34 | | |
| 35 | | |
| 36 | | |
| 37 | | |
| 38 | | |
| 39 | | |
| 40 | | |
| 41 | | |
| 42 | | |
| 43 | | |
| 44 | | |
| 45 | | |
| 46 | | |
| 47 | | |
| 48 | | |
| 49 | | |
| 50 | | |
| 51 | | |
| 52 | | |
| 53 | | |
| 54 | | |
| 55 | | |
| 56 | | |
| 57 | | |
| 58 | | |
| 59 | | |
| 60 | | |
| 61 | | |
| 62 | | |
| 63 | | |
| 64 | | |
| 65 | | |
| 66 | | |
| 67 | | |
| 68 | | |
| 69 | | |
| 70 | | |
| 71 | | |
| 72 | | |
| 73 | | |
| 74 | | |
| 75 | | |
| 76 | | |
| 77 | | |
| 78 | | |
| 79 | | |
| 80 | | |
| 81 | | |
| 82 | | |